

# Integrated Solar garden light

IES $\geq$ 135lm/W



Ra $\geq$ 75

IP65

CE

ROHS

AIO solar street light is an integrated of solar panel,LED light,lithium battery,controller and lighting housing , Daytime solar panel turn sunlight into electricity , with intelligent controlled technology store energy the daylight.During the night when the brightness decrease,solar panel working voltage less than 4V,the sensor will work automatically controller by intelligent induction module.lithium battery turn the electricity to light.Lithium battery discharge to the dawn of illumination increased, the solar panel working voltage is more than 4V, the charge and discharge controller action, lithium battery discharge (off the lights).



## Product picture and size :



### Product Feature :

- 1.High class Integrated Aluminum alloy case .
- 2.Lighting mode with motion sensor
- 3.360° view angle
- 4.Over 3 nights lighting after full charge
- 5.Easy to install,Auto on/off
- 6.With remote control , UVA technology , bring high corrosion resistance , 30m remote control operation , increase/decrease the brightness.

### Technology specification :

1. Lumen : 2700LM ( 20W Bridgelux chips3030 )
2. Solar Panel: 30W/18VHigh Efficiency Monocrystalline Silicon
3. LifePO4 Battery : 144WH/12.8V
4. LED Lamp : 3PCS LED Lamp/Each 24PCS LED Chips
5. Waterproof : IP65
6. Working temperture : -25°C~65°C
7. Material : Aluminium alloy
8. Charging time : 9-10by bright sunshine
9. Remote control : Yes
10. Install Pole diameter : 70-75mm
- 11.Mounting Height : 3-4M ( distance10-14M )
- 12.Warranty : 3 years

		<p><b>Product Feature :</b></p> <ol style="list-style-type: none"> <li>1.High class Integrated Aluminum alloy case .</li> <li>2.Lighting mode with motion sensor</li> <li>3.360° view angle</li> <li>4.Over 3 nights lighting after full charge</li> <li>5.Easy to install,Auto on/off</li> <li>6.With remote control , UVA technology , bring high corrosion resistance , 30m remote control operation , increase/decrease the brightness.</li> </ol> <p><b>Technology specification :</b></p> <ol style="list-style-type: none"> <li>1. Lumen : 4000LM ( 30W Bridgelux chips3030 )</li> <li>2. Solar Panel: 40W/18VHigh Efficiency Monocrystalline Silicon</li> <li>3. LifePO4 Battery : 320WH/12.8V</li> <li>4. LED Lamp:3PCS LED Lamp/Each 24PCS LED Chips</li> <li>5. Waterproof : IP65</li> <li>6. Working temperture : -25°C~65°C</li> <li>7. Material : Aluminium alloy</li> <li>8. Charging time : 9-10hours by bright sunshine</li> <li>9. Remote control : Yes</li> <li>10. Install Pole diameter : 70-75mm</li> <li>11.Mounting Height : 3-5M ( distance10-17M )</li> <li>12.Warranty : 3 years</li> </ol>
		<p><b>Product Feature :</b></p> <ol style="list-style-type: none"> <li>1.High class Integrated Aluminum alloy case .</li> <li>2.Lighting mode with motion sensor</li> <li>3.360° view angle</li> <li>4.Over 3 nights lighting after full charge</li> <li>5.Easy to install,Auto on/off</li> <li>6.With remote control , UVA technology , bring high corrosion resistance , 30m remote control operation , increase/decrease the brightness</li> </ol> <p><b>Technology specification :</b></p> <ol style="list-style-type: none"> <li>1. Lumen : 6700LM ( 50W Bridgelux chips3030 )</li> <li>2. Solar panel: 50W/18VHigh Efficiency Monocrystalline Silicon</li> <li>3. LifePO4 Battery : 420WH/12.8V</li> <li>4. LED Lamp:5PCS LED Lamp/Each 24PCS LED Chips</li> <li>5. Waterproof : IP65</li> <li>6. Working temperture : -25°C~65°C</li> <li>7. Material : Aluminium alloy</li> <li>8.Charging time : 9-10hours by bright sunshine</li> <li>9. Remote control : Yes</li> <li>10.Install Pole diameter : 70-75mm</li> <li>11. Mounting Height : 4-6M ( distance 14-21M )</li> <li>12.Warranty : 3 years</li> </ol>

Product Size Pictures:

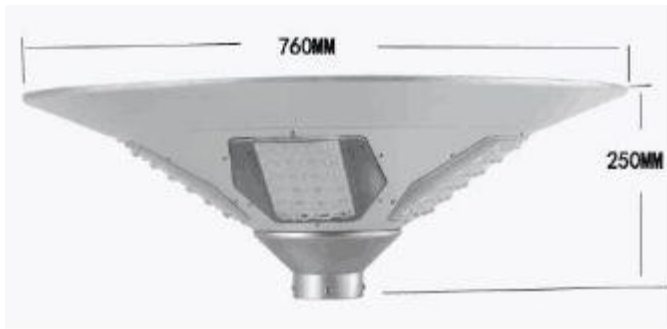

### Products Size Excel :

Model	Power	Size(mm)	
		Diameter ( mm )	Height ( mm )
JKC-J20	20W	Φ570	230
JKC-J30	30W	Φ660	240
JKC-J50	50W	Φ760	250

### Product Specification :

Model	Size(mm)	Power ( W )	CCT	Lumen ( lm/W )	Input Voltage	View Angel	LED Lamp	LED QTY
JKC-J20	Φ570*230MM	20	2700K - 6500K	≥135	12V	360°	SMD3030	72
JKC-J30	Φ660*240MM	30						72
JKC-J50	Φ760*250MM	50						120



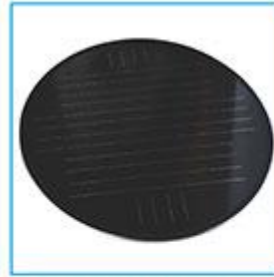

MONOCRYSTALLINE SILICON SOLAR PANEL



LITHIUM BATTERY



MPPT CONTROLLER



EPISTAR LED CHIPS

### REMOTE CONTROLLER



### HOW IS THE LIGHT WORKING ?

LIGHT SWITCH OFF FOR SUN CHARGING IN DAYTIME



ALWAYS BRIGHT LIGHTING FOR 5 HOURS



AFTER 7 HOURS BRIGHT LIGHTING THEN TURN ON DIM LIGHT TILL DOWN





Packing :

Model	Power	N.W	Carton Size	Qty/ctn	G.W/ctn
JKC-J20	20W	6.6kg	630*620*270 mm	1PCS	7.6kg
JKC-J30	30W	9kg	710*710*300 mm	1PCS	10kg
JKC-J50	50W	11.5kg	810*810*300 mm	1PCS	12.8kg



**Application:**

**Courtyard/Garden/Park/Street/Roadway/Pathway/Parking lot/Private road/Sidewalk/Public square/Plaza/Campus/Airfield/Perimeter security/Wildlife area/Military base**