

# EL-SL68



*The manufacturer reserves all rights to make changes in the materials and components used in its products. All data is subject to change without prior notice.  
The tolerance for all the given data is 10%.*

## Product Description:

- ELUX luminaire is the ideal solution that fulfils requirements of functional street lighting and residential areas, which working with outstanding heat dissipation and compact system. Equipped with high-quality electrical components, long lifetime is assured. Tool-free design and disconnecter device, enables easy, safe and minimal cost for maintenance. Efficient system also to reduce energy consumption and to create a more attractive urban living environment and visual comforts for public and residential areas.
- With patented housing design and range of optics, Elux series luminaire is also a perfect choice for project oriented usage.

## Features:

- Patented Ribbon-Free housing™ technology
- Excellent thermal management
- Outstanding self-cleaning capability
- Patented optics for increased application efficiency
- Tool-free maintenance

## Application:

- Highway roads
- Streets
- Parking lots
- Residential areas

## Specifications:

EL-SL68-Mini



EL-SL68-S



EL-SL68-M



EL-SL68-L



Model	EL-SL68-Mini(Mini version) EL-SL68-S(Small version) EL-SL68-M(Medium version) EL-SL68-L(Large version)
Light source	Integral LED Module
Power	30W/40W 50W/60W 80W/100W/120W 150W/180W/200W (Other power upon request)
Luminaire flux	1400-5500Lm(Mini version) 6500-7800Lm(Small version) 10000-16000Lm(Medium version) 19500-26000Lm(Large version)
Luminaire efficacy	110-140lm/W
CCT	4000K (3000K/5000K/5700K upon request)
CRI	> 70 > 80(upon request)
Lifetime	100,000 hours at 25°C ambient temperature
Operating temperature range	-30 to 45°C
Driver	Meanwell (Inventronics optional) Other brand of driver(upon request)
Electrical	Class I or Class II Input voltage: 90-305VAC/50-60Hz,170-305VAC/50-60Hz 10KV/20KV SPD Power automatically switch off when opening
Dimming	Dali 1-10V PWM AstroDIM for autonomous dimming with five independent levels Smart control management system
Options	Photocell Surge protection device (up to 20KV) 0.5m External cable(Other length upon request) Smart control device Motion detection
Materials	<b>Housing: ADC12 die-cast aluminum</b> <b>Cover: Toughened Glass</b> <b>Screws: 304 stainless screws</b>
Color	<b>Grey/ Black/ white</b>
Tightness level	<b>Ip66</b>
Impact Resistance	<b>Ik09</b>
Standards & Certifications	CE ENEC CB GS IEC ROHS LM80 LM79 TM21

## Luminous Intensity Distribution Diagram

The ELUX series LED street light luminaire come with a robust optic compartment design, enable many different options of LED chipset and optic lens modules, which will help customers to always cope with the latest development of efficiency of led by using different type of led package, from 3030, 3535 to 5050.

Option 1: with 3535 LED package, basically the ELUX could offer 6 standard light distribution curves as following

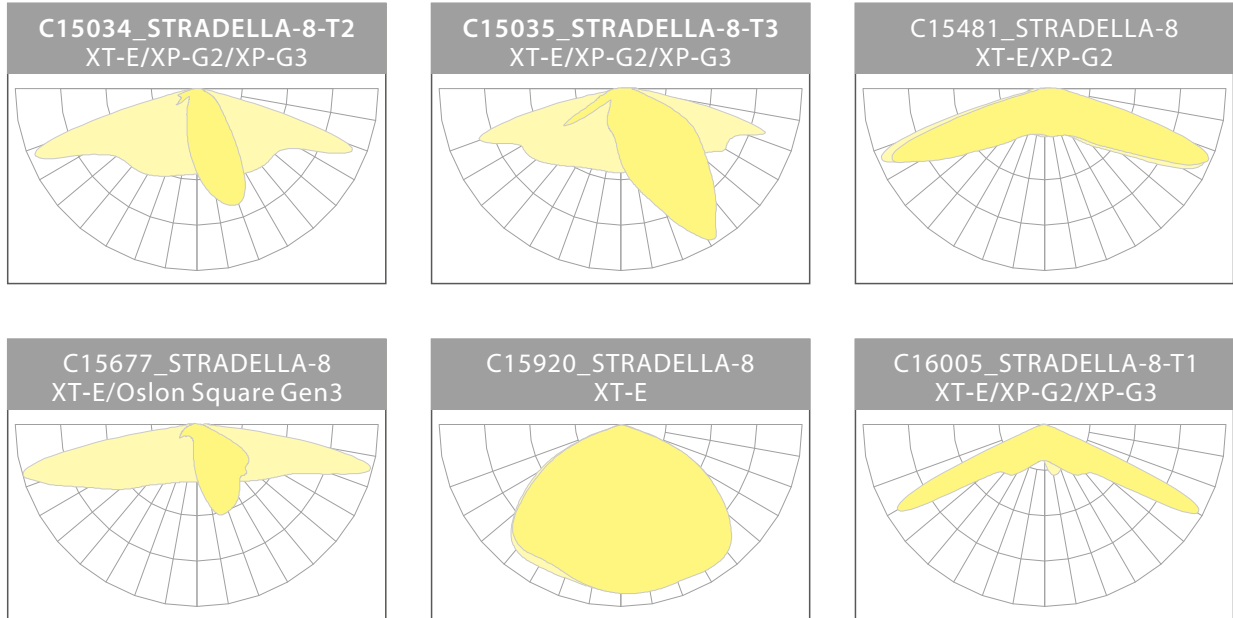

Option 2: with 5050 LED package, basically the ELUX could offer 26 standard light distribution curves as following

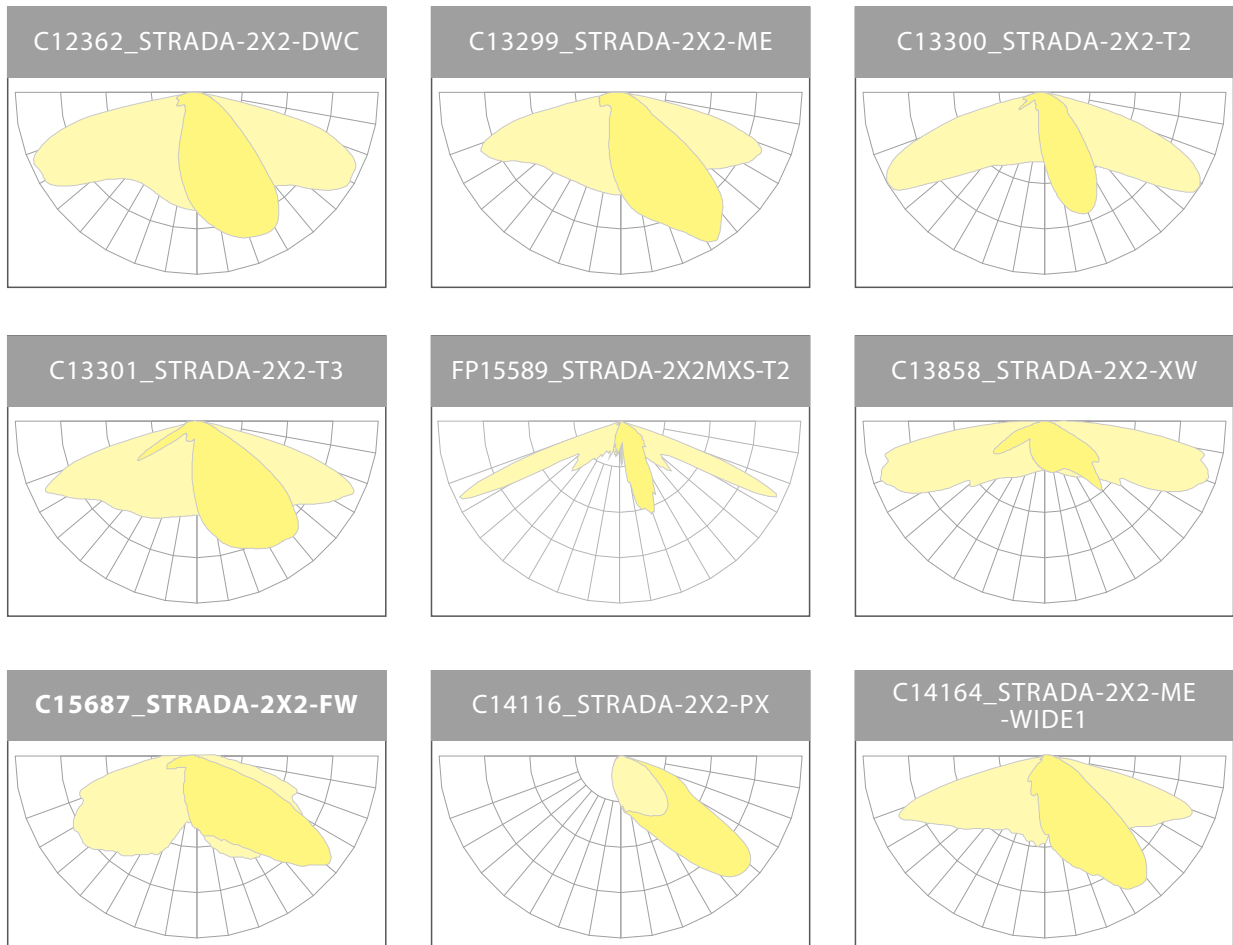

C14165\_STRADA-2X2-ME-WIDE2

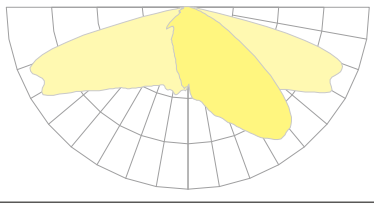

C14680\_STRADA-2X2-VSM

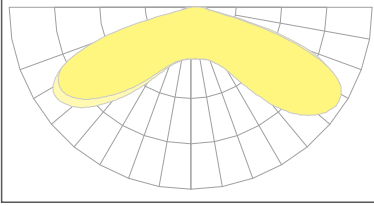

C14750\_STRADA-2X2-CAT

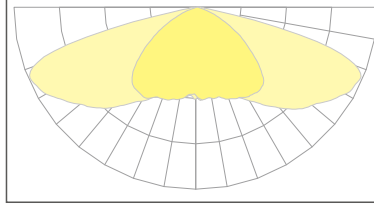

C14896\_STRADA-2X2-PXL

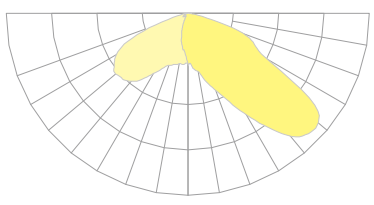

C15014\_STRADA-2X2-T4

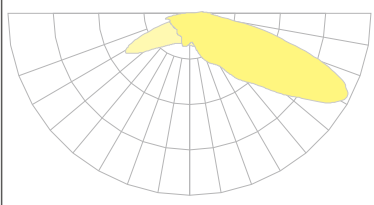

C15021\_STRADA-2X2-SCL

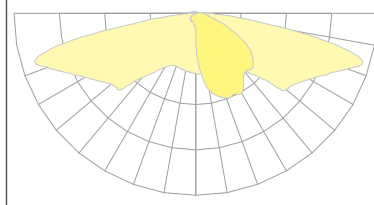

C15135\_STRADA-2X2-T1

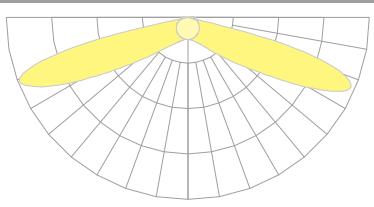

C15217\_STRADA-2X2-CAT-B

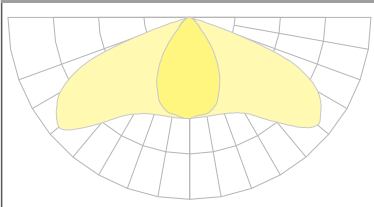

C15594\_STRADA-2X2-MEW

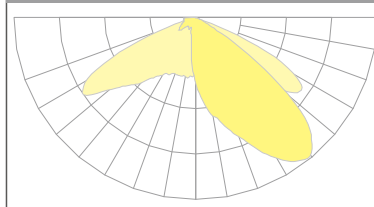

135-60 4H1

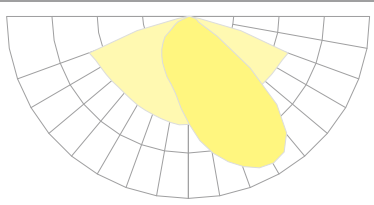

150-100 4H1

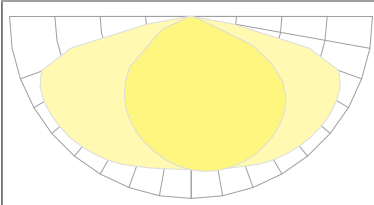

155-75 4H1

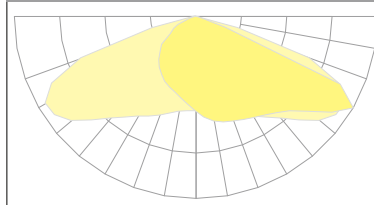

155-80 4H1

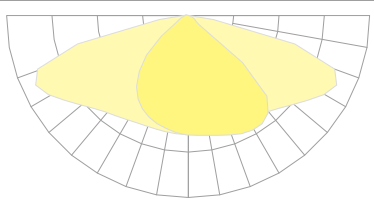

OS 2612 6H1

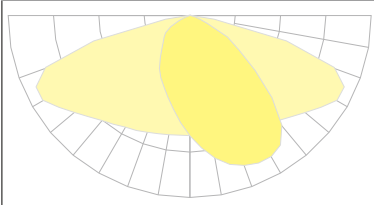

OS 2613 6H1

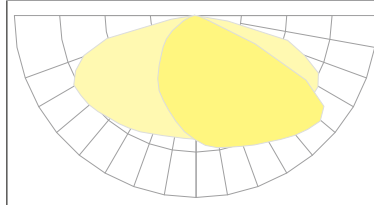

OS 2614 6H1

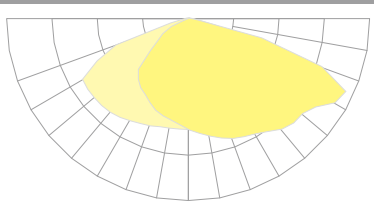

OS 2615 6H1

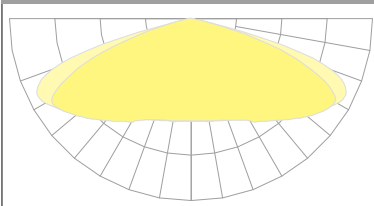

Option 3: with 3030 LED package, basically the ELUX could offer 9 standard light distribution curves as following

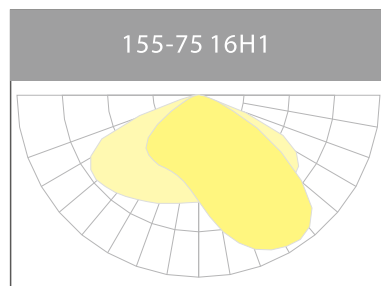
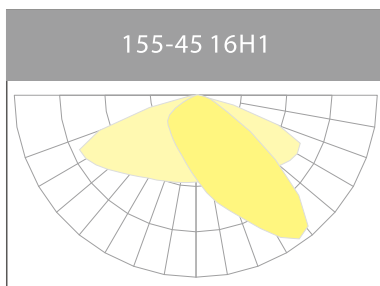
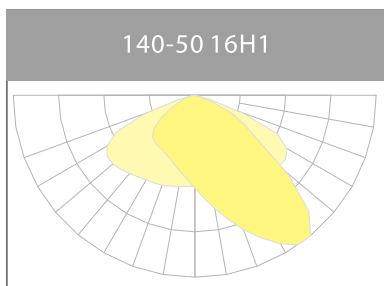
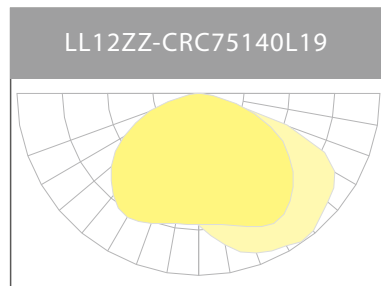
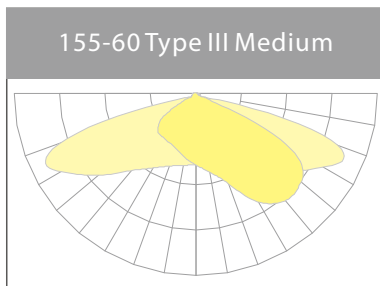
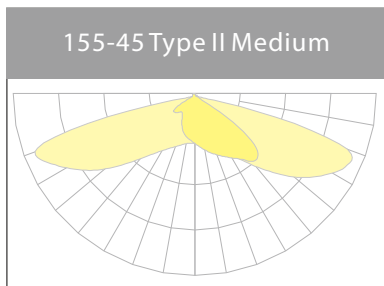
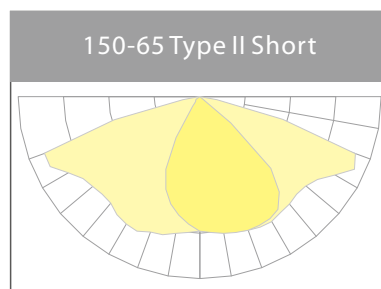
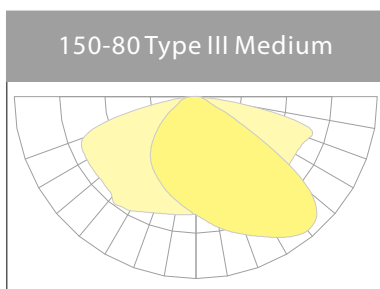
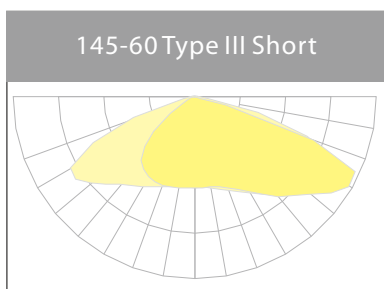

## Unique features of Elux LED street light luminaire Mini version



## Unique features of Elux LED street light luminaire Small/Medium/Large Version

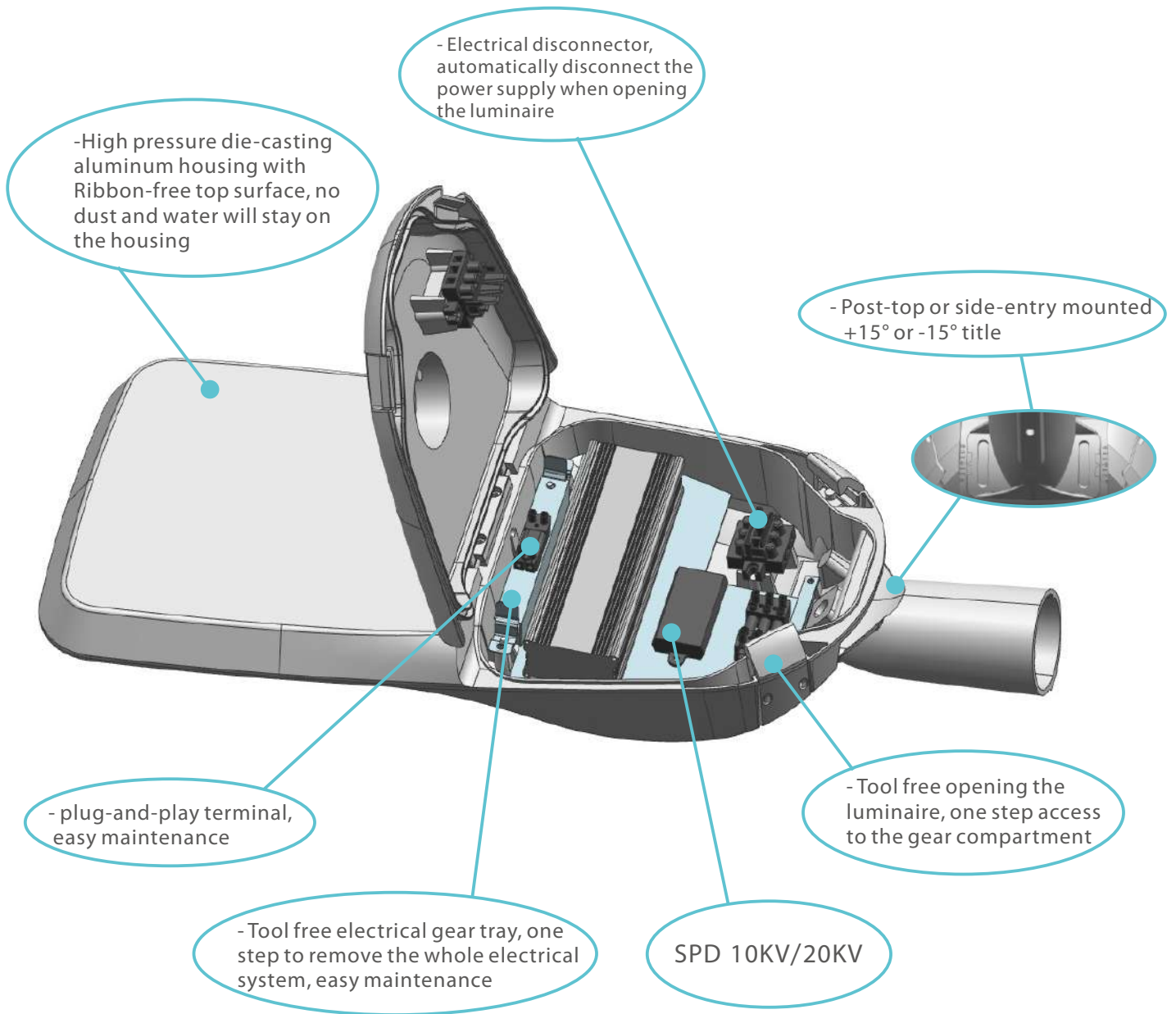

**Pictures:**

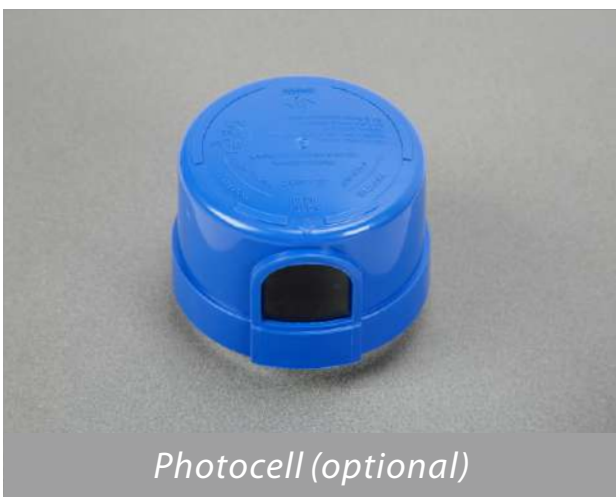
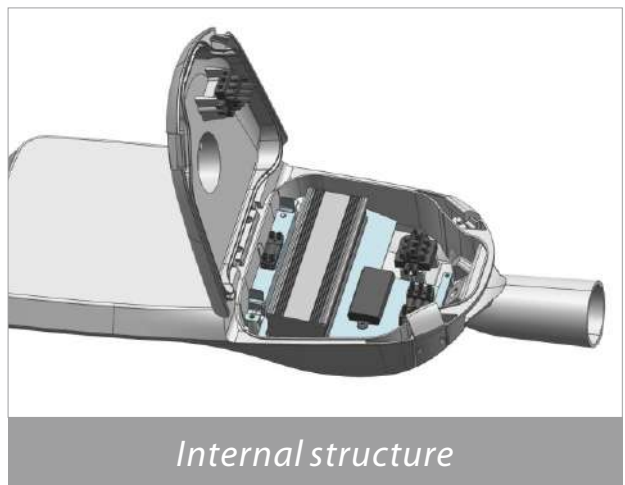



## Product size:

### Horizontal Installation

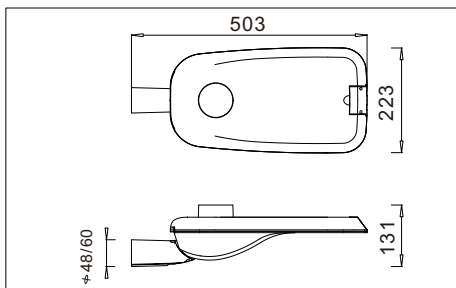
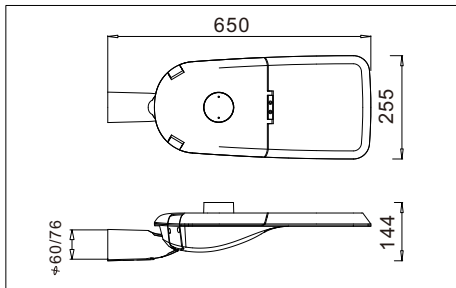
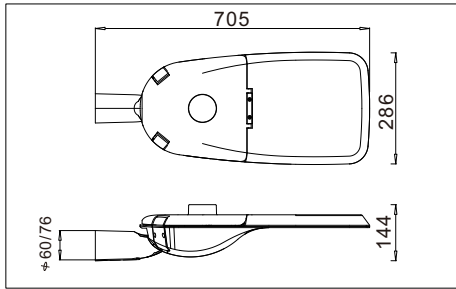
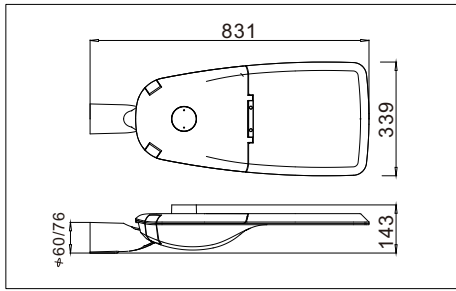

### Vertical Installation

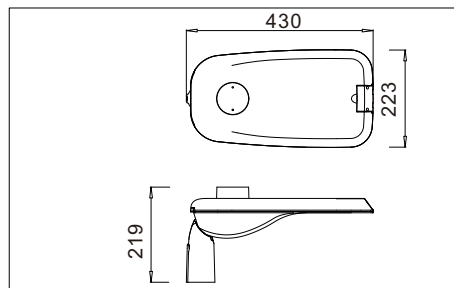
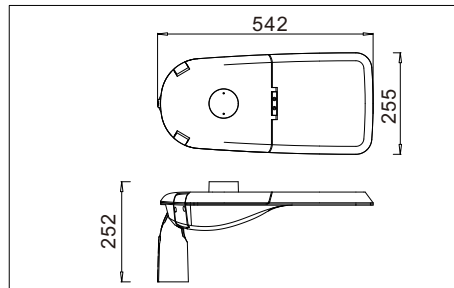
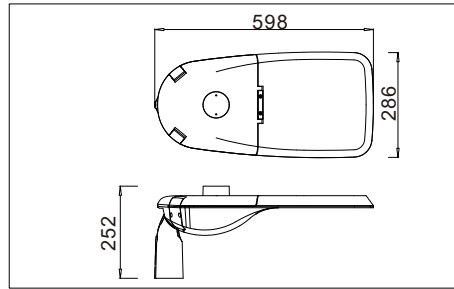
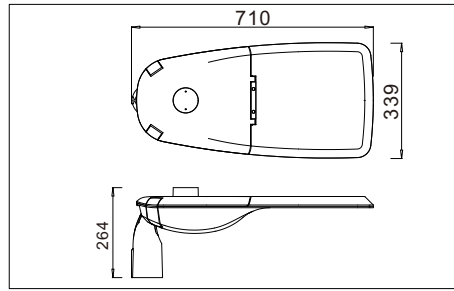

## Installation:

- The Elux luminaire can either be post-top or side-entry mounted.
- The Elux luminaires are fitted with an adjustable inclination system to facilitate photometric adjustments on-site for optimal photometric performance.
- 3 installation pipe diameters are available, 48/60/76mm.
- Please look at the following information to finish installation.

